



*Put Yourself in Power.*

**ELECTRICITY**  
**HEATING & COOLING EQUIPMENT**  
**HEATING OIL**

# **HEATING EQUIPMENT**

*Maintenance &  
Protection Plans*

*Schedule Your Annual Tune-up*  
**888 835 3535**

# Annual Tune-Up

## Silver

Annual Tune-up + Added Protection

## Tank Replacement Allowance

An allowance of \$1,000 is given towards our replacement of a leaking indoor Oil Tank.

### Combustion Efficiency Test + Inspect, Clean & Adjust

|                        |
|------------------------|
| Belt(s)                |
| CAD Cell Eye           |
| Chimney Base           |
| Electrodes             |
| Fan/Limit Control      |
| Filters                |
| Fuel Pump Strainer     |
| Heat Exchanger         |
| Lubrication            |
| Nozzle (replace)       |
| Oil Filter (replace)   |
| Oil Line (vacuum test) |
| Oil Line Fittings      |
| Oil Tank               |
| OSV Valve              |
| Pump Pressure          |
| Smoke Pipe             |
| Solenoid Valve         |
| Stack Relay            |
| Temperature Rise       |
| Thermostat             |
| Tube/End Cone          |

### Annual Tune-Up + Parts & Labor Coverage

|                                          |
|------------------------------------------|
| Air Eliminator (spirovent)               |
| Air Inlet Damper                         |
| Aquastats and Wells                      |
| Balancing Valve                          |
| Baseboard Leak Repair (where accessible) |
| Blower Bearings & Shaft                  |
| Blower Fan Belt                          |
| Blower Motor (up to 3/4 HP)              |
| Blower Motors Variable Speed             |
| Blower Pulleys                           |
| Blower Squirrel Cage                     |
| Boiler Back Flow Preventer               |
| Boiler Domestic Coil Gasket              |
| Boiler Domestic Relief Valve             |
| Boiler Domestic Restrictors              |
| Boiler Low Water Cut Off                 |
| Burner Blast Tube (air tube)             |
| Burner Bulk Head Fitting & Nut           |
| Burner Coupling                          |
| Burner Delayed Oil Valve                 |
| Burner Door Gasket                       |
| Burner End Cone                          |
| Burner Fan                               |
| Burner Flange Gasket                     |
| Burner Fuel Pump & Gaskets               |
| Burner Motor                             |
| Burner Nozzle, Adapter, Assembly & Line  |
| Burner Observation Door                  |
| Burner Porcelains                        |

|                                   |
|-----------------------------------|
| Burner Riello Hydraulic Jack      |
| Burner Static Plate               |
| Burner Strainer                   |
| Burner Universal Flange           |
| CAD Cell Eye                      |
| CAD Cell Holder                   |
| CAD Cell Relay                    |
| Capacitors                        |
| Circuit Board (printed)           |
| Circulator Coupling               |
| Circulator Motor (one per year)   |
| Combustion Chamber (3 GPH max)    |
| Draft Regulator up to 9" Diameter |
| Electrode Assembly                |
| Electrode Porcelains              |
| Electrodes/Igniters/Buss Bars     |
| Emergency Switch                  |
| Expansion Tank (drain as needed)  |
| Expansion Tank Valve              |
| Fan & Limit Control               |
| Fan Control Center                |
| Firematic Valve & Switch          |
| Firematic Switch                  |
| Flue Pipe Chimney Connector       |
| Ignition Transformer              |
| Ignition Transformer Terminals    |
| Ignition Wiring (minor)           |
| Low Voltage Transformer           |
| Oil Check Valve                   |

|                                              |
|----------------------------------------------|
| Oil Filter (element or cartridge)            |
| Oil Filter Complete                          |
| Oil Filter Gasket                            |
| Oil Safety Valve                             |
| Oil Tank Fill Cap                            |
| Oil Tank Gauge (above ground tank only)      |
| Oil Tank Vent Alarm (above ground tank only) |
| Oil Tank Vent Cap                            |
| Pressure Reducing Valve                      |
| Primary Control (stack relay)                |
| Stack Relay                                  |
| Steam Glass Gauge & Washers                  |
| Steam Safety Valve (1-1/4 in max)            |
| System 2000 Back Board                       |
| System 2000 Digital Sensor                   |
| System 2000 Dual Aquastat                    |
| System 2000 High Limit                       |
| System 2000 Manager                          |
| System 2000 Pac/Man                          |
| Thermostat (non-program)                     |

# Hot Water Heater

## Coverage

Provides repair coverage (parts & labor) to the following parts on oil fired hot water heaters when they become defective due to normal wear and use:

- Aquastat
- Blast Tube
- Burner Coupling
- Burner End Cone
- CAD Cell, Holder & Relay
- Circulator Pump
- Delayed Oil Valves
- Electrodes & Assembly
- Emergency & Firematic Thermal Switch
- Fuel Oil Cartridge
- Ignition Cables & Transformer
- Nozzle Adapter & Assembly
- Oil Burner Fan, Motor, Nozzle, Pump & Strainer
- Stack Relay & Temp/Pressure Relief Valve

# Stay Warm All Winter Long

## Typical Furnace

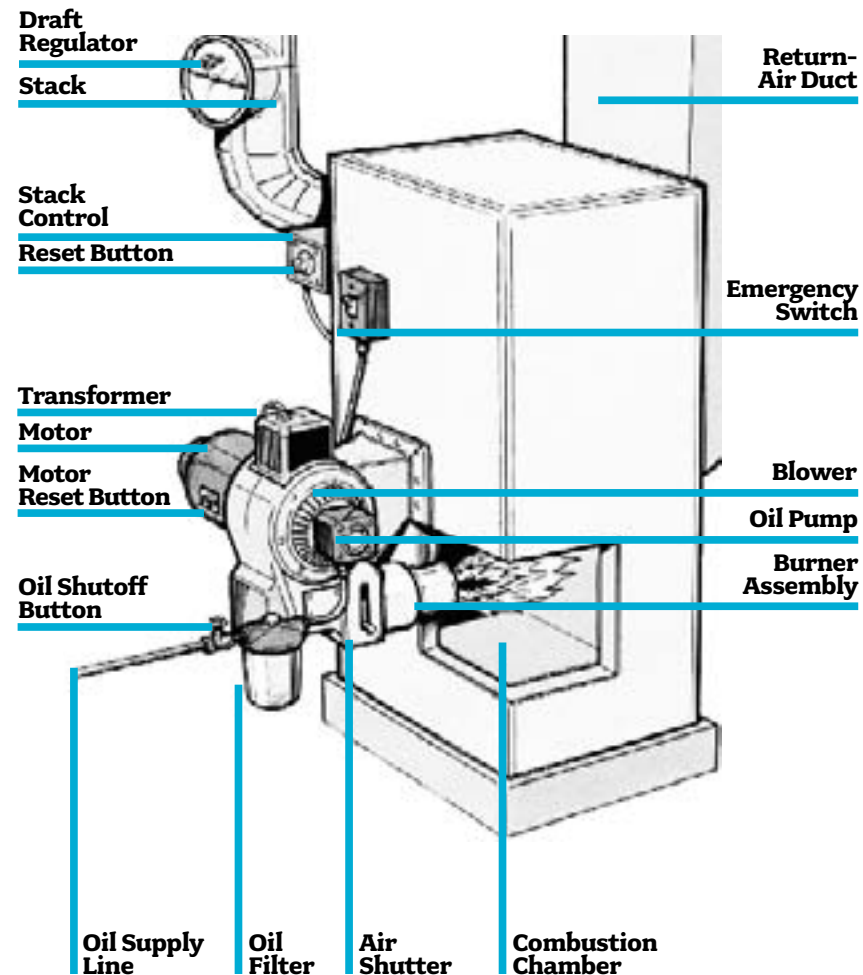

A well maintained system not only keeps you warmer, but also reduces your energy consumption. Included in all of our plans is an annual inspection and preventative maintenance; which ensures your heating system is operating at peak efficiency.

**888 835 3535**  
**DDMEnergy.com**



841 Lincoln Avenue  
West Chester, PA 19380  
HIC # PA015690

## Terms & Conditions

*The plans described herein have the following conditions:*

This agreement is only available to customers who purchase their entire fuel oil requirements from the Company, on an automatic delivery basis. The cancellation of automatic oil deliveries immediately cancels this agreement.

This agreement cancels and supersedes all prior agreements between the parties for burner service if such existed. This agreement is subject to an inspection by our service department to new plan holders or upon an upgrade in coverage to a higher level service plan. The inspection may take place at any time up to and including the time of the first service call. Initial repairs required to put the burner in an acceptable condition are not covered. Buyer to pay any charges set by federal, state, city or local government.

Heating season is defined as October 1st to April 30th. Normal service hours are Monday through Friday, 8am – 5pm excluding weekends and holidays. Emergency service is defined as no heat, no hot water, serious oil leaks or other dangerous situations. Non-emergency calls and calls during business hours for non-covered parts/service under this agreement will be billed at prevailing rates. Scheduled tune-ups are available under this agreement during normal service hours. This agreement provides coverage to ordinary residential or comparable commercial installation up to 3 gallons per hour for the specific parts listed. This agreement specifically does not cover GE low pressure and rotary burners and other obsolete equipment, and parts that are obsolete or inaccessible. Calls for service when burner is off due to low water in boiler, electrical service is not available, thermostat set improperly, blown or loose fuses, circuit breakers or switches off and restricted or plugged chimney are not covered. The customer must provide adequate boiler room ventilation for proper combustion, and any asbestos-containing materials must be removed by the customer. This agreement does not cover vacant or unattended homes.

The Company shall not be liable for, and the customer agrees to hold the Company harmless from any and all claims, charges, losses and damages for personal injury and/or property damage, including but not limited to freezing of pipes resulting from delays and/or failure to perform, failure to secure obsolete parts and failure to secure any parts or materials from suppliers. The Company will not be held liable for any incidental or consequential damage, including but not limited to, environmental damage caused by or resulting from any cause. The Company will also not be liable for Acts of God, government, acts of enemies, strikes, riots, labor difficulties, fires, floods or any cause beyond the Company's control, whether similar or dissimilar to the foregoing nor shall the Company in any event be liable to the customer for any personal injury or property damage arising out of or in any way connected with or relating to the performance of this agreement or failure to supply oil (run out) when the customer fails to make payment for fuel oil and/or service within terms.

This agreement is for one year and will be automatically renewed for successive one year terms, unless a 30-day written notice is given by either party prior to the expiration date. Such renewal shall be subject to any price changes by the Company and prevailing at the time of renewal. This agreement is not written on a prorated basis and no refund will be made if cancelled prior to normal expiration date.

This agreement may be cancelled within 30 days of acceptance without liability against either party, except the customer's liability to the Company for services rendered and parts furnished at its regular rates. This agreement may also be canceled by either party, with notice, at any time. If the customer discontinues purchase of fuel oil requirements from the Company, or oil burner is altered, repaired or tampered with by others in any way that, in the opinion of the Company, affects reliability or detracts from the performance of the burner, this agreement will automatically and immediately terminate. The Company also reserves the right to terminate this agreement if the customer fails to remedy conditions identified by the Company as a hazard to life or property. This agreement may not be assigned by the customer without the Company's written consent. Rendering service in any instance shall not be deemed a waiver of the provisions of this agreement as to any other instance.